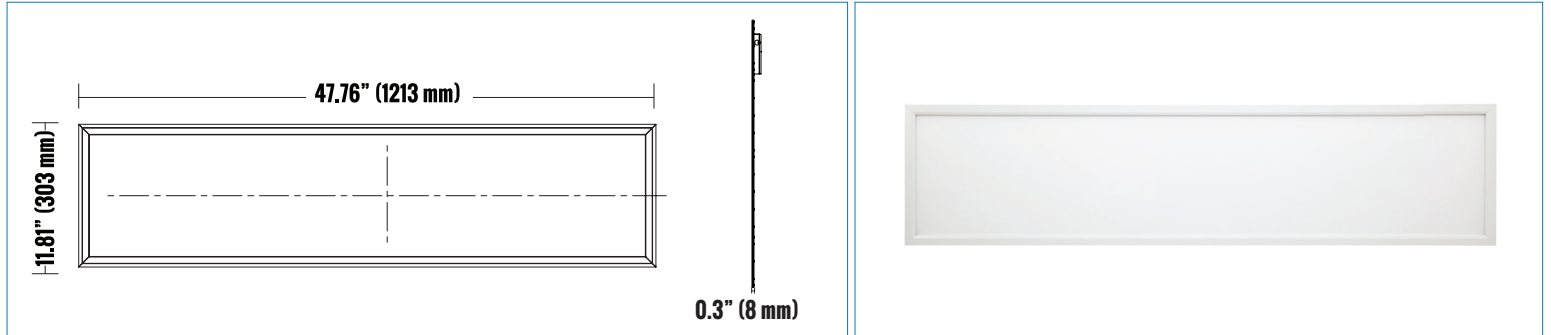

PRODUCT CODE: RTP4214-40U50-WH
1X4 LED ULTRA SLIM FLAT PANEL TROFFER

PRODUCT DESCRIPTION

The Etlin-Daniels RTP4214-40U50-WH Ultra-Slim LED Flat Panel Troffer offers improved illumination, energy savings and reduced maintenance over traditional fluorescent fixtures. The Edge-Lit, high performance PMMA lens provides for even and glare-free lighting.

This new generation is available in both 4000K & 5000K, in 1x4, 2x2, and 2x4 panel size - 120-277V. With 3 mounting options available - recessed, surface and suspended - our LED panels will compliment any office, educational, healthcare, commercial or industrial application, whether they be used to retrofit and upgrade the look of an existing site, or installed in a new-build. For further energy savings, take advantage of the 0-10V Continuous Dimming.

FEATURES

- Indoor LED Light Source
- Light weight, durable aluminum and polycarbonate housing.
- Edge-Lit PMMA surface illumination with glare-free uniformity.
- Flicker free performance.
- Recessed, Surface and Suspended Mounting available.
- 120-277V.
- Damp location rated.
- Earthquake clips for secure recessed installation.
- Seamless frame design.
- 0-10V Continuous Dimming.
- 5 year warranty.
- L70 - 50,000 hours.
- DLC Standard.

SOLD IN PACKAGES OF 2 UNITS

PRODUCT SPECIFICATIONS (OPTICAL DATA)							PRODUCT SPECIFICATIONS (ELECTRICAL DATA)				
LED TYPE	LED QTY	SYSTEM EFFICACY	LUMENS	COLOR TEMPERATURE	BEAM ANGLE	CRI	VOLTAGE	POWER FREQ.	POWER EFFICIENCY	POWER FACTOR	HARMONIC DISTORTION
13S16P	208 CHIPS	100LM/W	4000LM	5000K	115°	>80CRI	AC120~277V	50~60HZ	>97%	>0.90	<30%

PRODUCT SPECIFICATIONS						
WATTAGE	FIXTURE MATERIAL	LIFE SPAN	STORAGE TEMP	OPERATING TEMP	PRODUCT DIMENSIONS	CARTON SIZE
40W	ALUMINUM	>50,000 HOURS	- 20°C-70°C - 4°F-158°F	- 20°C~40°C - 4°F~104°F	47.76 X 11.81 X 0.3 INCHES (1213 X 8 X 303 MM)	51.29 X 7.87 X 16.14 INCHES (1303 X 200 X 410 MM)

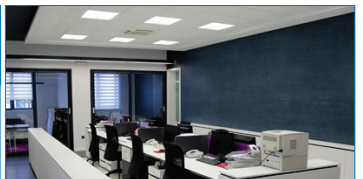

ADDITIONAL INFORMATION	INSTALLATION METHOD	FIXTURE COLOR	CONTROL TYPE
	RECESSED/SURFACE/SUSPENDED	WHITE ALUMINUM FRAME	0-10V CONTINUOUS DIMMING

PRODUCT CODE: RTP4214-40U50-WH

1X4 LED ULTRA SLIM FLAT PANEL TROFFER

LUMINAIRE PHOTOMETRIC (TEST REPORT)

ILLUMINANCE (AT A DISTANCE) FLUX OUT: 3293LM

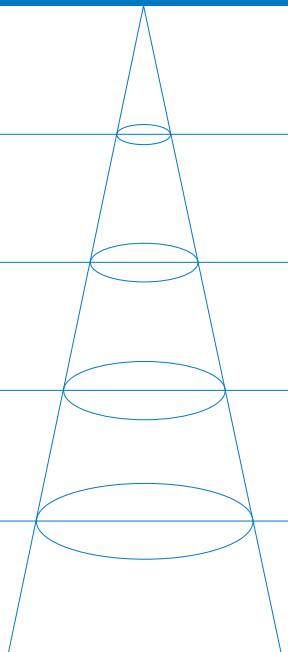
3.281FT 1M	32.46, 132.0FC 351.1, 1425LX		10.93FT 333.11CM
6.562FT 2M	8.116, 33.01FC 87.36, 355.3LX		21.86FT 666.22CM
9.843FT 3M	3.607, 14.67FC 38.82, 157.9LX		32.97FT 999.33CM
13.12FT 4M	2.029, 8.253FC 21.84, 88.83LX		43.72FT 1332.45CM
16.4FT 5M	1.298, 5.282FC 13.98, 56.85LX		54.64FT 1665.56CM
HT	EAVG/EMAX	ANGLE: 118.04DEG	DIA

LUMINOUS INTENSITY DISTRIBUTION DIAGRAM

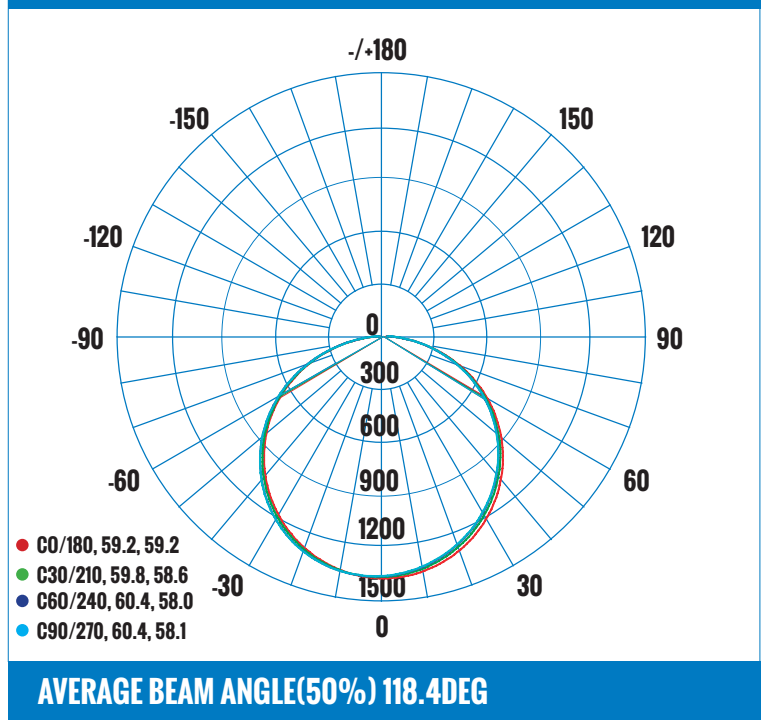

CERTIFICATIONS



DRIVER/LED CHIP

SAMSUNG



MOUNTING OPTIONS



ORDERING INFORMATION - RTP4 SERIES

SERIES	DLC TYPE	SIZE	WATTS	VOLTAGE	COLOR TEMPERATURE	DIMMABLE	FINISH
E.G. RTP	42	14	40	U	5	0	WH
RTP - SLIM	42- DLC4	14- 1X4	40 - 40W	U - 120-277V	5 - 5000K	0 - 0-10V	WH - WHITE
PANEL TROFFER						CONTINUOUS DIMMING	

Head Office - 1850 Wilson Ave. - Toronto, ON - M9M 1A1 - Tel: 416.741.7336 - Fax: 416.741.9104

Toll Free: in Canada. 1.800.661.9610 - in USA. 1.888.762.5384 (SOCKETS4U)

www.etlin-daniels.com - For sales/service questions - sales@etlin.com